

Pathfinder Fair MANUAL 2010



South Queensland Conference of SDA – John Sommerfeld

TASTE and SEE

Contents

1	IMPORTANT INFORMATION.....	2
2	PREPARED WORK OF ART: <i>TASTE & SEE THAT THE LORD IS GOOD</i>	3
3	OPENING CEREMONY: COUNTDOWN	4
4	NIBBLE, DRIBBLE & SCRIBBLE.....	5
5	BABY TONGUE OF TERROR - BABY TOT	7
6	THE TONGUE OF TERROR - BABY TOT GROWS UP.....	9
7	TOAD IN THE HOLE	11
8	CLACK CLACK CLACK.....	12
9	PANCAKE STORM.....	12

Attachments:

- Brainstorming Session Form
- Program Outline

The Spirit of the Pathfinder Fair.

Our Conference has a reputation of having great Pathfinder Fair Days. This is because it is a partnership between our God, our leaders, our Pathfinders and our supporters.

It promises to be another great day. Please, never forget, that the Day is for our Pathfinders. Give them a go. Involve them all. Encourage them. Lead by example, and most of all - have fun!

1 Important Information

Please read this information carefully and apply it to your Pathfinders and supporters.

The Venue

The Venue will be the Main Oval of the North Pine Christian College which is adjacent to the Watson Park Campground.

Some Clubs have indicated an interest in staying at the Campground. Separate arrangements will need to be made with the Campground staff. The phone number is (07) 3204 6544.

Each Club will be allocated a spot around the oval. These are to act as a 'Base Station' for Clubs and place for their supporters to socialise and provide encouragement. This year we will be making a number of equal-sized *Super Clubs* by uniting Clubs. All Clubs within each *Super Club* will be placed together.

Participation

Participation is most important. Larger clubs are invited to have more than one entry in some Activities. See the following Activities. The Club will be scored on the entry with the highest score.

Pathfinder Good Manners.

Our friends have been gracious to let us use their facilities, so we need to demonstrate good manners.

- The college / church / campground area will be strictly out-of-bounds unless permission is given. We will have security there to make sure this happens.
- We must respect all property.
- The area must be left clean and in good condition when we leave.

Other Important Information.

Please make sure that everyone is aware of and abides by the following:

- Who is in charge: At these events, we often find that – with parents present – there is confusion over who is in charge (parents or Pathfinder staff). Please make this clear to all attending.
- The Sun: We are most conscious of this. Everyone will need sun protection (hats, sunscreen, shade etc). Watch out for those who will be handing out Points to those who shine in this area.
- Feet Protection: We expect suitable footwear to be worn at all times.
- What to Bring: Please refer to the Activities for details. You will notice that, as in previous years, an important requirement is bush poles – four (4) bush poles, each 2.4 metres long and four (4) bush poles, each 1.2 metres long. Of course, don't forget sufficient ropes for lashings. Don't forget your Field Uniforms.

2 Prepared Work of Art: *Taste & See that the Lord is Good*

The Challenge: {One Entry Per Club}

To produce a creative work of Art – *Taste & See that the Lord is Good*

We will be displaying them at the Fair. It will be worthwhile looking at them through lunch.

The Work-of-Art must:

- Have a title. That is "Taste & See that the Lord is Good".
- Be constructed solely of metal. Other materials cannot be more than 3% of the total mass or size.
- Be of size no greater than four (4) A4 pages. We'll leave the shape up to your creativity. Note that an A4 page is approx 200 x 300 mm. The judges will be impressed by 3 dimensions!
- Have the names of everyone in your Club on it and written by on them.
- Have the Club name on it so it can be identified.

Needed

Metals that can be made into a 'work-of-art'.

NB. We are more interested in creativity than sophisticated metalwork

Details

- (a) Run a brainstorming session/s using the Brainstorming Session Form as guide.
- (b) Complete the *Brainstorming Session Form*.
- (c) Leave Work-of-Art and *Brainstorming Form* at the Admin Area before the Fair.
- (d) Collect the Work-of-Art at the end of the Fair

Details: 'Taste & See that the Lord is Good'	Points	Points Awarded
Presented before Opening Ceremony	10	
Brainstorming Form (ideas / depth of thought etc)	0 to 20	
Work-of-Art has a title	5	
Club name is attached to Work-of-Art	10	
At least 97% of the Work-of-Art is metal	0 to 10	
Club Member's names, written on by them.	0 to 10	
Size no greater than stated size (ie four (4) A4 pages.	5	
Ingenuity and creativity	0 to 20	
Bonus points for other worthy features.	0 to 10	
	<i>Total:</i>	

3 OPENING CEREMONY: COUNTDOWN

The Challenge:

- To have your Club lined up, ready for inspection and ready to march onto the parade ground at the appointed times. See below.
- To have your Club marching at their best onto the Parade Ground.

Needed:

- All members of the Club. This includes all Staff and Pathfinders
- All members of the Club in Field Uniform

Details:

1. We have a Fair Day tradition of counting down to the start of our Opening Ceremony.

<u>Count-down</u>	<u>Time</u>	<u>Event</u>
- 1000	9:15 am	Clubs formed-up for Club inspections.
Zero	9:30 am	Start of Opening Ceremony

2. On the day, Clubs will be designated a position on which to form-up ready for Inspection. They will march from here onto the parade ground. It is most important that they are there before the inspection time of the count-down. See points score below.
3. The start will be signalled by a 'Blast Off' at Count-down Time 'Zero'. We think you will hear it.
4. After the 'Blast Off' signal, the order to go on Parade will be given. Club Directors, you are then to march your Club along the designated course and onto your position on parade.

Score Details: "Opening Ceremony: Countdown"	Points	Points Awarded
Club <u>All</u> formed up at Inspection Count-down time (ie – 1000).	30	30
Club lined up properly (straight lines, equal spacing, sized etc)	0 to 10	10
Club in field uniform including hats	0 to 10	10
Club starts to march all together	0 to 10	10
Quality of turns (ie left / right / inclines) on march to position	0 to 10	10
Club marches in step	0 to 10	10
Club marchers keep straight lines (except on turns) and equal spacing	0 to 10	10
General presentation	0 to 10	10
		0
<i>Grand Total</i>		<i>100</i>
CLUB:	JUDGE:	

4 NIBBLE, DRIBBLE & SCRIBBLE

The Challenge: {Maximum of 2 entries per Club}

To identify several different tastes using a *Taste Testing Rig* which your club has made.

Note: Small Clubs may 'borrow' helpers to help carry the *Sample Delivery Module*. See the Judge

Needed

- Bush poles (4 of the 2.4m ones and 4 of the 1.2m ones).
- Sufficient rope to make lashings.
- A very clean and hygienic teaspoon. This is essential.
- Something to attach the teaspoon to the pole. See diagram for location.
- Felt Pen/s and stiff pieces of cardboard. Suggest a decent-sized old cardboard box.
- Eye protection and blindfolds / protector cloth for each taster.
- All members of the Club and one, two or three Pathfinders who are willing to be *Tasters*
- A responsible person delegated to direct proceedings – called *Inspector Nibble*

Details

Part A. Construction and Set Up

1. Although all the materials and equipment can be laid out before the activity starts, no construction can start before the given signal. Anyone who starts before the signal will lose all points for the activity.
2. The *Taste Testing Rig* is to be constructed as per the diagram using the appropriate lashings. There are two parts; *Sample Delivery Module* and the *Safety Barrier*. In the diagram, the *Sample Delivery Module* is resting on the *Safety Barrier* and is about to rotate and drop the sample into the mouth of the blind-folded *Taster*. The *Sample Delivery Module* will end up over 6 metres long so make sure the lashings are very well done.

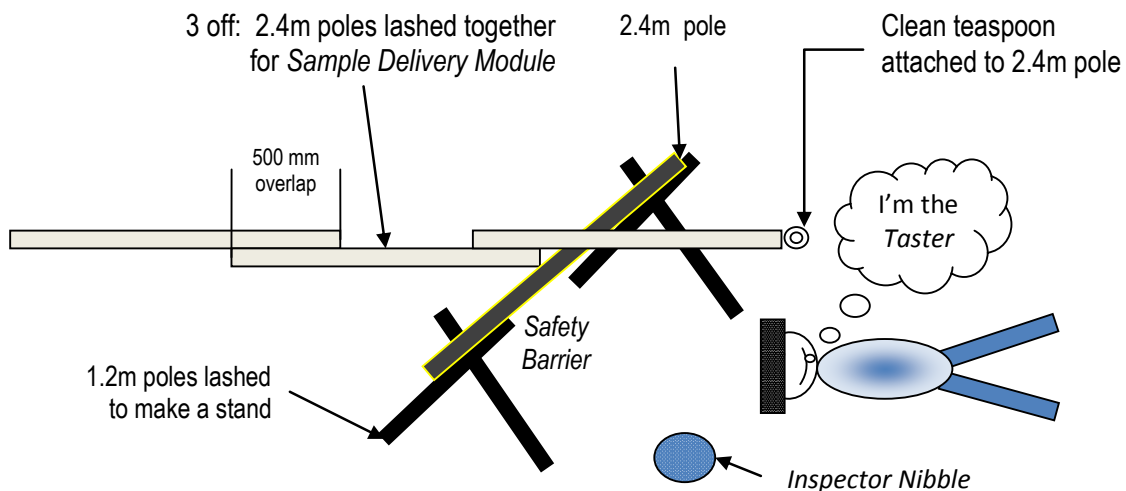

3. The *Safety Barrier* is to be placed 25 metres away from the 'starting line'

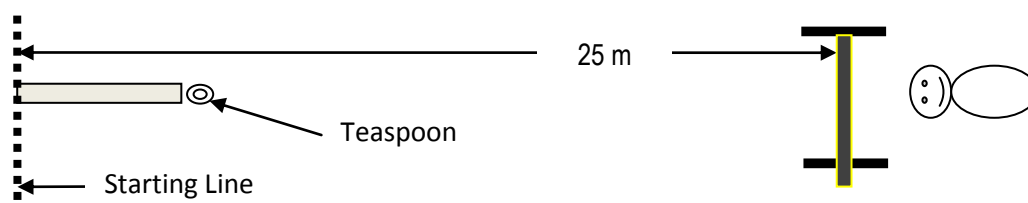

Part B. Assessing as suitable for operation

- The whole *Taste Testing Rig* will be assessed as suitable for operation. With the exception of the *Taster*, everything must be in position. Taste testing will not commence until everything is passed as suitable for operation.

Part B. The Tasting Process

- The responsible person (ie *Inspector Nibble*) is given identification. He / she will be readily recognisable. The Club gives suitable recognition to *Inspector Nibble*.
- The *Taster* lies on the ground, face upward with feet facing in the direction shown in the diagram. Sunglasses (or glasses) are to be worn and a blindfold / cloth is to be placed over the eyes. The *Taster's* mouth is about 1 metre behind the *Safety Barrier*. A felt pen is fixed to the *Taster's* shoe ready for communicating the type of taste.
- The Judge gives *Inspector Nibble* a sample to be identified.
NB Samples will only include: PURE WATER, LEMONADE, LEMON JUICE, SODA WATER, MINERAL WATER, SUGAR-SWEETENED WATER or SALTY WATER.
- All other members of the Club are required to operate the *Sample Delivery Module*. It will be raised to approx 1 metre. The sample is placed in the teaspoon by *Inspector Nibble* who now directs all operations. The pace will be no more than slow walking pace. If the *Sample Delivery Module* needs refilling, it must be returned to the starting line.
- When the *Sample Delivery Module* reaches the *Safety Barrier*, *Inspector Nibble* goes behind the *Safety Barrier* and near the *Taster* as an additional safety precaution. *Inspector Nibble* is the only one allowed to speak.
- The *Sample Delivery Module* is passed over the *Safety Barrier* and carefully rotated, letting the sample dribble into the *Taster's* mouth. The Club waits while the *Taster* identifies the sample and writes what is using the felt pen strapped to his / her foot. **THE TASTER CANNOT SPEAK.** The *Inspector Nibble* may help.
- The Judge advises if the identification is correct. If so, points are awarded. If not, the process is repeated once. Depending on time, there will be a total of 3 samples tested.

Score Details: "Nibble, Dribble & Scribble"	Points	Points Awarded
<i>Taste Testing Rig</i> completed within 15 minutes	10	
<i>Taste Testing Rig</i> passed as suitable for operation	20	
Activity set up properly (see diagram previous page for distances)	20	
<i>Inspector Nibble</i> suitably identified and given recognition.	0 to 10	
<i>Taster</i> in position and properly attired	10	
Taste test 1 correct (20 first attempt, 10 second attempt)		
Taste test 2 correct (20 first attempt, 10 second attempt)		
Taste test 3 correct (20 first attempt, 10 second attempt)		
Extra Points: Full participation and keeping to the rules.	0 to 10	
Extra Points: Teaspoon kept clean and hygienic	0 to 10	
<i>Grand Total</i>		
CLUB:	JUDGE:	

5 BABY TONGUE OF TERROR - Baby TOT

The Challenge:

To create *Baby Tongue of Terror* (ie *Baby TOT*) involving all members of the Club and to show off what *Baby TOT* can do.

Note: For a small Club, the Judge can approve the number of bush poles that are to be used. For Larger Clubs, please find a creative way to involve everyone.

Needed:

- Four (4) of the 2.4m bush poles and ropes for lashings. Use the *Sample Delivery Module* from the previous Activity. Also, please see point 2 in Details Section below.
- Sufficient rope for lashings
- Any appropriate ornaments to make your performance memorable.
- All Pathfinders and leaders within the Club.

Details:

Part A. Construction and Set Up

1. The diagram shows how the *Baby Tongue of Terror* is to be constructed. Four (4) of the 2.4m bush poles are to be lashed together as shown. The poles will need 500 mm overlap.

Please be careful as *Baby TOT* will be over 8m long.

The maroon circles broadly represent Pathfinders and their leaders carrying *Baby TOT*.

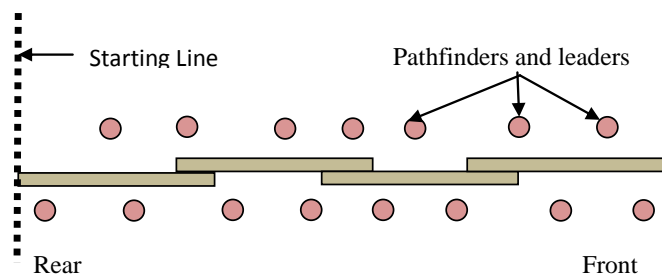

2. The Judges will inspect the *Baby TOT* for suitability of operation. It will be placed in position at the *Starting Line*.

Part B. The Performance

3. One (1) person only must give commands. The exception is an emergency situation.

Very few of us are experienced with the antics of a *Baby TOT* so the following will be enforced. Failure to comply could lead to disqualification.

- ✓ Pace: 60 beats per minute (ie 60 steps per min). Unless advised otherwise.
- ✓ Length of Step: 400 to 450 mm
- ✓ Maximum Height of *Baby TOT* above the ground: 1.5 metres

4. Actions of *Baby TOT*

As there is not sufficient room for all Clubs to perform at once, we will call about six Clubs to perform at the one time. Wait your turn and enjoy the performance of others.

PATHFINDER FAIR 2010: "TASTE & SEE"

Clubs will be required to perform a creative routine (Time 2 to 3 minutes) using a selection of the following. It starts and finishes at the *Starting Line*. Hint. Have a look at the scores allocated below.

- a) Formation of those who carry *Baby TOT*. Includes everyone in the Club
 - Tallest at the front, down to the least-tall at the rear or vice versa
 - Females at the front, males at the rear or vice versa
- b) Lifting *Baby TOT*
 - Even raise (Ie *Baby TOT* remains parallel to the ground)
 - Raise front first, then raise rear to a maximum height of 1.5m or vice versa
- c) *Baby TOT* on the travel. All must be in step.
 - Straight ahead
 - Left / Right wheel. Front must stop, while the rear swings around. Take care.
- d) Antics of *Baby TOT*
 - Here's an opportunity to be at your most creative. Some suggestions: a tantrum, trying unsuccessfully to create terror, 'drinking' from a bottle etc etc.

Score Details: Baby Tongue of Terror - Baby TOT	Points	Points Awarded
Previous activity dismantled and <i>Baby TOT</i> created in 10 minutes.	0 to 10	
<i>Baby ToT</i> passed as OK to do performance	20	
Only one person giving commands	20	
All in step and pace is correct (60 beats per minute)	0 to 20	
Formation: Two changes of up to 10 points each	0 to 20	
<i>Lifting Baby TOT</i> : Two changes of up to 10 points each	0 to 20	
<i>Baby TOT</i> on the travel: Two turns of up to 10 points each	0 to 20	
Antics of <i>Baby TOT</i>	0 to 20	
Length of performance is 2 to 3 min & finishes at starting line	10	
Participation and enthusiasm	0 to 20	
Creativity	0 to 20	
<i>Grand Total</i>		
CLUB:	JUDGE:	

6 THE TONGUE OF TERROR - Baby TOT Grows Up

The Challenge:

- To create a fearsome *Tongue of Terror* involving all members of the Clubs in the *Super Club*
- To work together 'escorting' the *Tongue of Terror* in an entertaining, creative and safe way.

Needed:

- Twelve (12) of the 2.4m bush poles and ropes for lashings
- Any appropriate ornaments likely to cast fear into the hearts of Pastor Steve and Pastor Willie
- Sufficient rope for lashings
- All Pathfinders and leaders within the *Super Club*.

Details:

Part A. Getting to know you

1. We will allow about 10 minutes for those in the Clubs comprising the *Super Clubs* to make their acquaintance and formulate the best way to do things together.

Part B. Construction and Set Up

2. The diagram below shows how the *Tongue of Terror* is to be constructed. Twelve (12) of the 2.4m bush poles are to be lashed together as shown. The poles will need 500 mm overlap. Please be careful as the *Tongue* will be over 23m long. That's why it has been called the *Tongue of Terror*.

The maroon circles represent Pathfinders and their leaders carrying the *Tongue of Terror* in escort mode. More on that later. Notice that the front pole has no one carrying it.

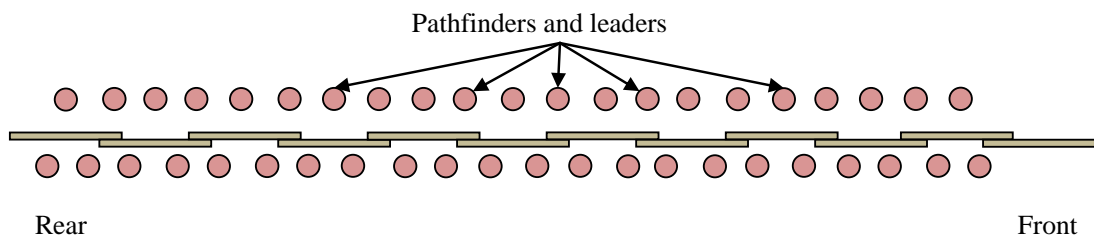

3. The next diagram shows the construction of *The Mouth*. Twelve (12) of the 1.2 m bush poles are lashed as shown opposite. Note the extended bottom horizontal poles which serve as carrying handles. If you can find a way to make it look more 'authentic' please do so.

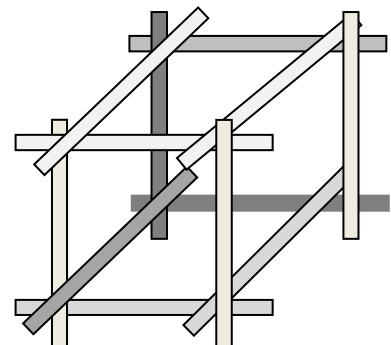

4. The judges will inspect the *Tongue of Terror* and *The Mouth* for suitability of operation.

Part C. Rehearsal at Fair Day

5. This is so important that we will be awarding points. **One** person must be elected as the only one who rules and gives the commands. All commands must be obeyed. The exception is an emergency situation. This ruler's name is *Baron (or Baroness) Big Lick.* (Note. Any association with persons at the Pathfinder Fair who have this name is unintended)

Baron/ess Big Lick will have clearly visible identification befitting this rank.

As with *Baby TOT*, the following will be enforced. Failure to comply could lead to disqualification.

- ✓ Pace: 60 beats per minute (ie 60 steps per min). Unless advised otherwise.
- ✓ Length of Step: 400 to 450 mm
- ✓ Maximum Height of *Tongue of Terror* above the ground: 1.5 metres

Routines

Routines will be the same as for *Baby TOT* with the following addition

Passing through *The Mouth*

- The *Tongue of Terror* passes part-way or all the way through *The Mouth*.

Part D. The *Tongue of Terror* Stalks the Earth

6. We will be giving full details of what will be required on the day of the Fair. Following is a broad concept of the travel path. This will include a separate score.

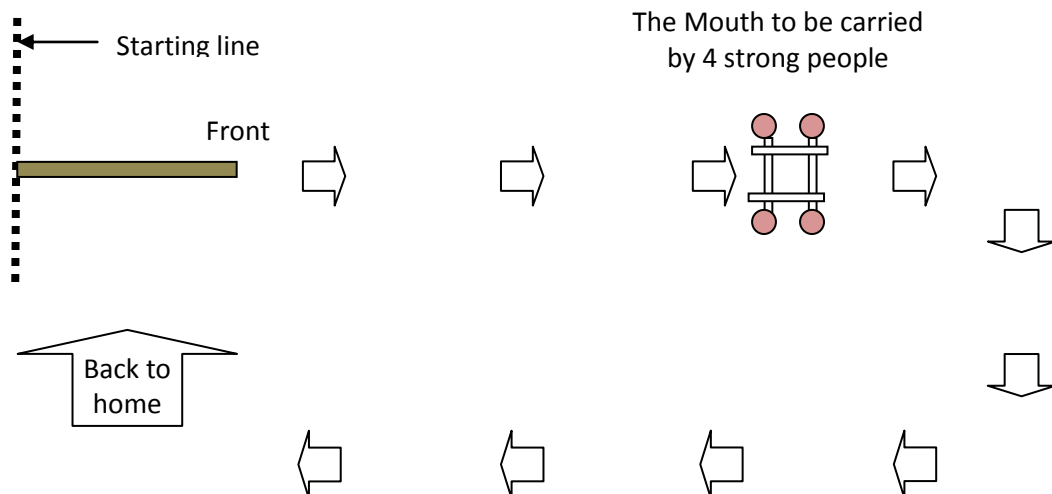

Part E. Judging the Activity

We will be assigning more than one judge to the *Tongue of Terror* Activity.

Scoring will be of two parts:

- I. Points scored overall by the *Super Club* as a whole
- II. Bonus points scored by individual members of the Clubs within the *Super Club*. Judges will be looking out for field uniforms.

7 TOAD IN THE HOLE

More than one Camp Oven may be used as long as the following conditions are adhered to. Please advise us on your *Intention to Attend* form so we can have sufficient supplies on hand.

The Challenge:

To acquire the ingredients and cook to perfection that Camp Oven Culinary Delight 'Toad in the Hole'. Please note that this is a vegetarian dish.

For information on Camp Oven Cooking, please see: <http://honours.adventistconnect.org/camp-oven>

Needed:

- A Camp Oven lid (or equivalent) and utensils such as egg lifter etc and a cutting knife.
- Fuel to burn. Strongly recommend hardwood / heat beads to make coals. Heat beads are best in this situation. Don't forget matches or kindling if you need it.
- Cooking oil
- A platform to keep the fire off the ground and to prevent damage to the grass. Suggested options are:
 - Sand on a sheet of corrugated iron (approx 0.6m x 0.6m) placed on bricks
 - Sand on a 20 litre oil drum cut in half (lengthways) and placed on bricks.
- Pancake mix. This is not compulsory, but it would be nice to have a pancake bake-off over lunch if you could. Better still, it could involve all the Clubs of the *Super Club*. It would be a good social event and give the Pathfinders many memories.

Details:

Part A. Construction and Set Up. Do on a Club Basis. Max time 10 minutes

1. First set up the Camp Oven lid on its platform above the ground with heat beads / hardwood in place.

DO NOT LIGHT THE FIRE YET.

2. Create a no-go zone which is comprised of a circle of radius 1.2m around the Camp Oven Lid. A rope pegged to the ground is preferred. Only the designated cook and one helper may be inside this circle at any time.
3. The judge will inspect the set-up and record on the score sheet that it is OK to proceed.
4. On the given signal from the dais, ignite the fire. Don't forget hygiene!

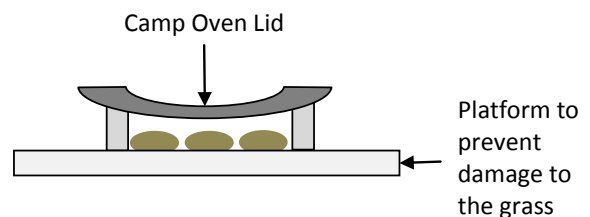

Part B. Firing up the Camp Oven Lid

5. When instructed from the dais, start the fire.

Part C. Getting the Ingredients. To do on a Super Club Basis

6. The entire *Super Club* will be required to perform that horrible song? "Why are we waiting?" It will start quietly and increase in tempo until the Judges are sufficiently impressed to give some information as to the bread and eggs to be used for the *Toad in the Hole*. The *Tongue of Terror* will be put to use.

Part D. Culinary and Super Club Activity

- When the ingredients are brought back, a toad shape is to be created and the egg placed in the 'centre' of the 'toad'.

Again. Don't forget to comply with the rules of hygiene.

While the *Toad in the Hole* is being cooked, we will be having an activity for those not directly involved with cooking. All will be revealed on the day.

Details: Toad in the Hole	Points	Points Awarded
Camp Oven Lid and fire and no-go zone set up properly. All OK	30	
Contribution to <i>Super Club</i> 's rendition of 'Why are we waiting'	0 to 20	
Contribution to <i>Super Club</i> 's getting the ingredients.	0 to 20	
Hygiene	0 to 30	
Shape of Toad in the Hole – likeness to a toad	0 to 20	
Finished product – Toad in the Hole	0 to 20	
Contribution to Super Club Activity	0 to 20	
No damage to Lawn	0 to 20	
All 'mess' including fire area cleaned up properly	0 to 20	
	<u>Grand Total:</u>	
CLUB:	JUDGE:	

8 CLACK CLACK CLACK

The Challenge:

This will involve the *Super Club*

Needed:

We will provide all that is required.

Details:

- All will be revealed on the day. Hint: Something to chew on

9 PANCAKE STORM

All will be revealed on the day. Another Activity involving the *Super Clubs*.